



INSTALLATION GUIDE

HYCON: The Hygienic Stainless Steel Cable Containment System

Address

DUNREIDY ENGINEERING
LIMITED KILKENNY 53
Hebron Industrial Estate
Kilkenny Ireland

Contact

P: Int + 353 (0)56 777 1377
F: Int + 353 (0)56 777 1380
www.dunreidy.com
enquiries@dunreidy.com

HYCON is a patented product by Dunreidy Engineering and is certified by U.L. (Underwriters Laboratories USA). Classification Coding 444411664414 and to European standard EN 50086.*

Contents

Contents.....	1
Introduction.....	3
ACCREDITATIONS.....	3
HYCON INSTALLATION IMPORTANT NOTICE.....	3
HYCON O & HYCON S	4
HYCON O	4
HYCON S.....	4
HYCON O Installation Procedure.....	5
1. CHOOSING THE CORRECT SIZE OF HYCON O CONDUIT.....	5
2. MEASURING AND CUTTING PRIOR TO INSTALLATION	5
3. FINAL FIT	6
4. BRACKETING.....	7
4.1. STANDARD BRACKET.....	7
4.2. EXTENDED BRACKET.....	7
4.3. CLIP TO CLIP USING BSP NIPPLE	8
4.4. OPTIONAL CLEAN ROOM BRACKET	8
5. FLASHING DISCS / ROSETTES.....	9
6. HYCON BULKHEAD FITTINGS.....	10
7. INSPECTION BOXES	11
DIMENSIONS	11
8. SOCKET AND BUSH	12
9. FOOT PLATE.....	13
10. Expander/Reducer	14
11. Inserts	15
HYCON S Installation Procedure	16

Choosing the correct size of HYCON S	16
APPLICATION OF SEALANT	18
PHOTOGRAPHIC ILLUSTRATIONS	19

INTRODUCTION

HYCON is a hygienic stainless-steel cable/pneumatic containment system designed for clean or harsh environment industries such as Pharmaceutical; Biotechnology; Chemical; Food Processing; Nuclear; Petrochemical and many others. The product has been developed, designed and patented by Dunreidy Engineering Limited in Ireland. For further information visit our web site at www.dunreidy.com

ACCREDITATIONS



HYCON is certified to both: European Standard EN50086 and U.L. classification coding 444411664414

HYCON INSTALLATION IMPORTANT NOTICE

HYCON manufactured products are subject to routine inspection by Underwriters Laboratory USA (U.L.). This is to ensure that HYCON products are manufactured in accordance with the European and US standards above. HYCON products are only available from Dunreidy Engineering Limited or their appointed agents. See our website for further information www.dunreidy.com The use of other products to substitute for HYCON products in a HYCON specified installation will result in the above certification being 'Null and Void'. This does not prohibit the use of Certified Panels, Boxes or JB's etc. 'HYCON' is a patented product by Dunreidy Engineering and is certified by U.L. (Underwriters Laboratories USA) Classification Coding 444411664414 and to European standard EN 50086. HYCON is now recognised worldwide as the Number 1 cable containment product for Cleanroom, Process and Harsh Environment installations. In order to achieve the 'Quality Finish' it is imperative that the installers know and understand HYCON. We strongly recommend that all installation personnel spend one day at our training facility in Kilkenny, Ireland; or alternatively we can provide training and certification at your preferred location. Training outside Ireland will be provided by Dunreidy Engineering personnel or their approved agents.

HYCON is a patented product by Dunreidy Engineering and is certified by U.L. (Underwriters Laboratories USA) UL Classification Code: In accordance with European Standard EN -IEC 61386-1 AND ** IEC 61386-21, IEC 61386-22, IEC 61386-23, IEC 61386-24 and/or IEC 61386-25, "STAINLESS STEEL CONDUIT" or "STAINLESS STEEL CONDUIT FITTING" [18EC] Dunreidy Engineering Limited: Classification Coding: 444411664414 and to European standard EN 50086

HYCON O & HYCON S

There are two types of HYCON product – HYCON ‘O’ and HYCON ‘S’

HYCON O

This system incorporates a push together method using joiners. HYCON O has an IP rating of IP66. HYCON O is made from 316L grade stainless steel.

DIAGRAM 1

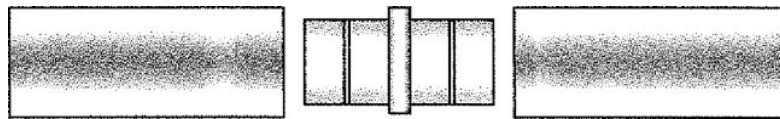

HYCON S

HYCON S is an overlap system. The overlap allows one conduit to slip snugly inside the other. HYCON S has an IP rating of IP66 when sealed with the HYCON sealing agent (see photographs). HYCON S is made from 316L grade stainless steel.

DIAGRAM 2



PLEASE NOTE:

A 3D model of all HYCON components O and S including accessories is available on request from Dunreidy Engineering Limited.

This will allow the specifier to use 3D modelling at the design stage thus creating a Bill of Quantities and a costing.

HYCON O INSTALLATION PROCEDURE

As with any installation, preparation is the most important stage. To achieve a proper installation care should be taken to ensure that all conditions are taken into consideration. Outlined below are the basic recommendations for the proper installation of HYCON O.

1. CHOOSING THE CORRECT SIZE OF HYCON O CONDUIT.

- 1.1. It is important to liaise with the End User to identify the type and size of cables or pneumatic tubes which will be used for the final installation
- 1.2. When all necessary details are agreed, it is time to select which HYCON will best suit the application
- 1.3. It is recommended that a 20% factor be used to allow for any further works.

2. MEASURING AND CUTTING PRIOR TO INSTALLATION

- 2.1. Conduit lengths when measured should allow a little extra to allow for final cleaning of the cut face.
- 2.2. To ensure a good square cut, cutting should be carried out using a suitable cutting tool, i.e. 'Axxair' rotary saw, or equivalent.
- 2.3. After cutting, the piece should then be 'Squared and Faced Off' using a suitable tool, i.e. 'Wachs Squaring and Facing Tool', or equivalent
- 2.4. In some cases it may be necessary to 'Deburr' the prepared piece. This is carried out using (a) Sharp file for external edges, always ensuring not to round over the conduit wall and (b) a deburring tool for internal edges. (See photographs later)

3. FINAL FIT

Important Notice! HYCON bonding agent (Loctite 638) is used to add extra strength to the installation and must be applied as shown in Diagram 3. This will ensure rigidity when installing cables etc.

3.1. The installation of a 'Joiner' or 'Socket and Bush' into its final position will require gentle tapping using a nylon headed mallet. Earth continuity checks should now be performed using the appropriate certified meter. Bonded joints can be opened with an industrial heat gun without damage to the O-ring or cables.

3.2. Final joints should appear seamless and have a smooth finish (see Diagram 4)

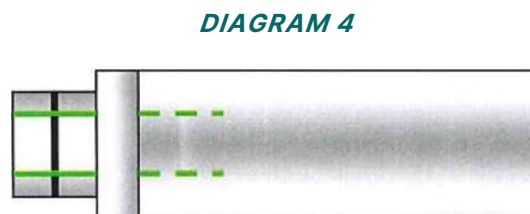
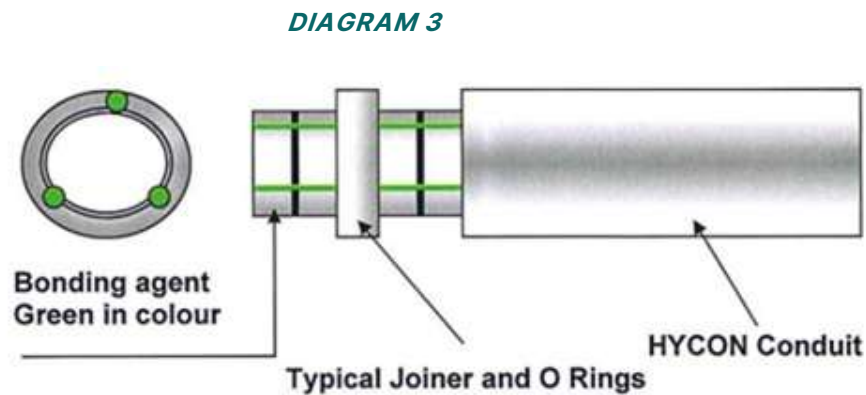

4. BRACKETING

4.1. STANDARD BRACKET

DIAGRAM 5

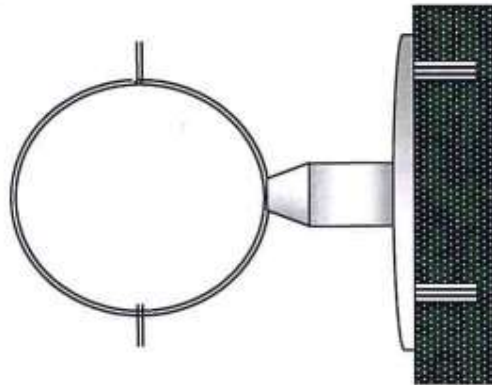

4.2. EXTENDED BRACKET

DIAGRAM 6

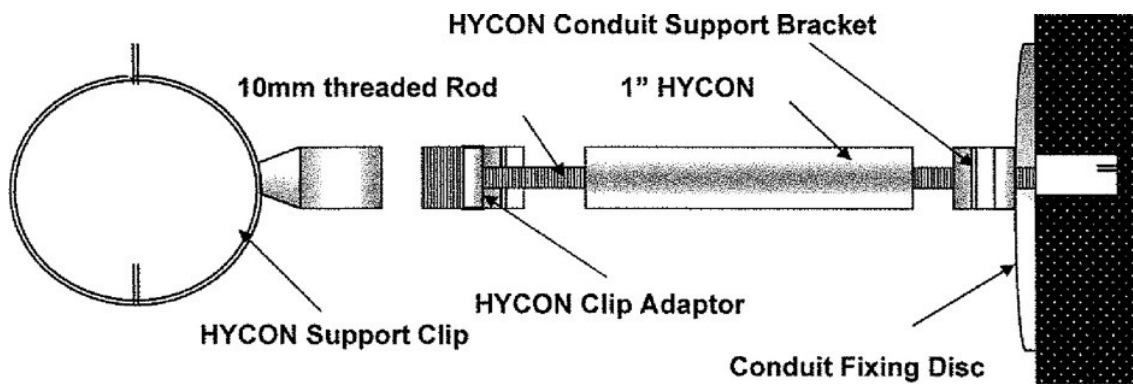

HYCON is a patented product by Dunreidy Engineering and is certified by U.L. (Underwriters Laboratories USA) UL Classification Code: In accordance with European Standard EN -IEC 61386-1 AND ** IEC 61386-21, IEC 61386-22, IEC 61386-23, IEC 61386-24 and/or IEC 61386-25, "STAINLESS STEEL CONDUIT" or "STAINLESS STEEL CONDUIT FITTING" [18EC] Dunreidy Engineering Limited: Classification Coding: 444411664414 and to European standard EN 50086

4.3. CLIP TO CLIP USING BSP NIPPLE

DIAGRAM 7

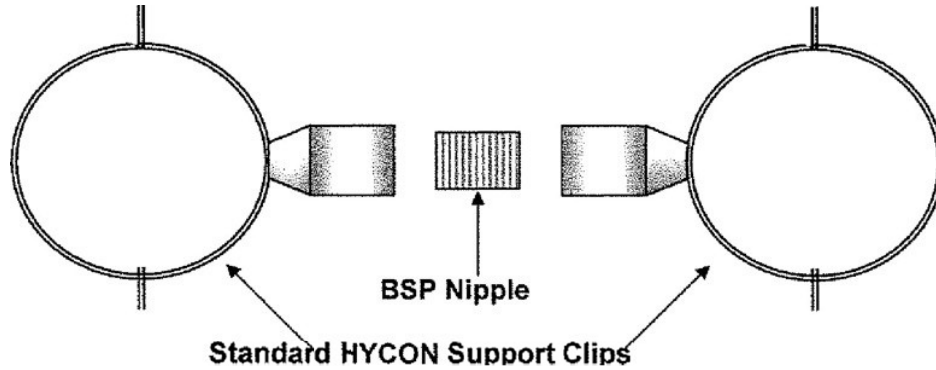

4.4. OPTIONAL CLEAN ROOM BRACKET

DIAGRAM 8

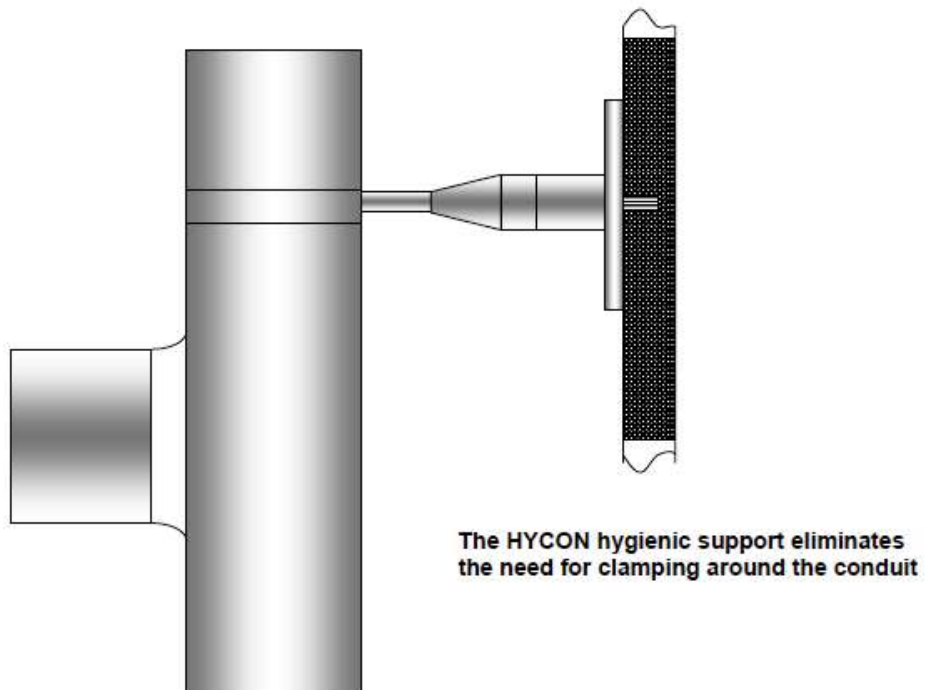

HYCON is a patented product by Dunreidy Engineering and is certified by U.L. (Underwriters Laboratories USA) UL Classification Code: In accordance with European Standard EN -IEC 61386-1 AND ** IEC 61386-21, IEC 61386-22, IEC 61386-23, IEC 61386-24 and/or IEC 61386-25, "STAINLESS STEEL CONDUIT" or "STAINLESS STEEL CONDUIT FITTING" [18EC] Dunreidy Engineering Limited: Classification Coding: 444411664414 and to European standard EN 50086

5. FLASHING DISCS / ROSETTES

These are used whenever a conduit passes through a wall or ceiling to ensure a clean finish around any opens. They may be secured by using an adhesive or screw fixed (Diagram 9).

DIAGRAM 9

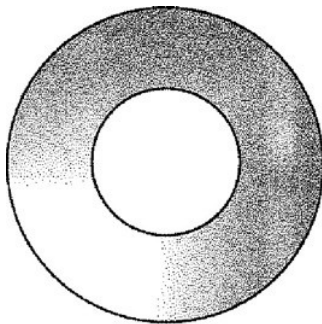

**Type 1
Plain**

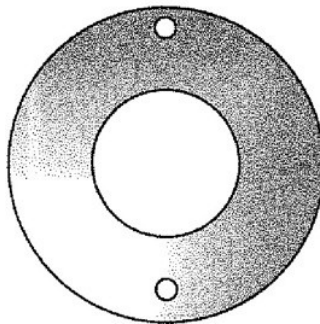

**Type 2
(2 no. counter sunk
holes)**

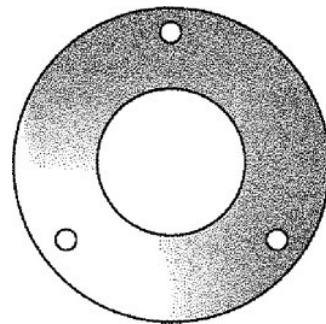

Type 23

6. HYCON BULKHEAD FITTINGS

The HYCON bulkhead fitting is used to exit/enter through a ceiling, wall or floor. The bulkhead is secured by means of a screwed locknut. A load bearing washer is provided as an option when bracketing/support space underneath the ceiling is restricted. The HYCON bulkhead allows for ceilings to be finished before work is complete in the cleanroom (see Diagram 10)

DIAGRAM 10

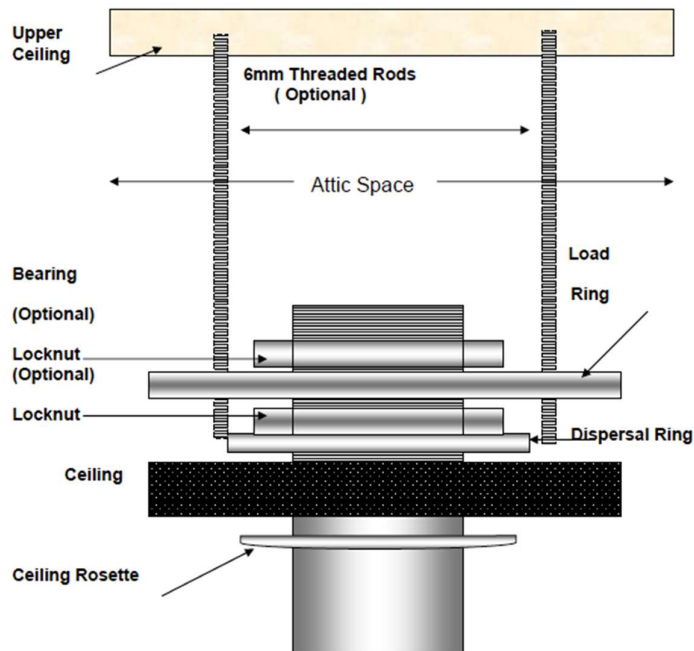

NB: Because the ceiling rosette is fixed, it is important to know the depth of ceiling/wall. This is to ensure the 'threaded portion' of HYCON is correct and will tighten securely.

7. INSPECTION BOXES

Inspection boxes should be used in some locations to act as access points within the HYCON system and enable easier installation of cables etc. These boxes are available in three types as standard. Types A, B and C (see dimensions in the table below). Boxes can be supplied pre-drilled or blank. Other sizes are available to suit customer requirements, on request.

DIMENSIONS

	Height	Width	Depth
Type A	80	160	80
Type B	100	200	100
Type C	150	200	150

DIAGRAM 11

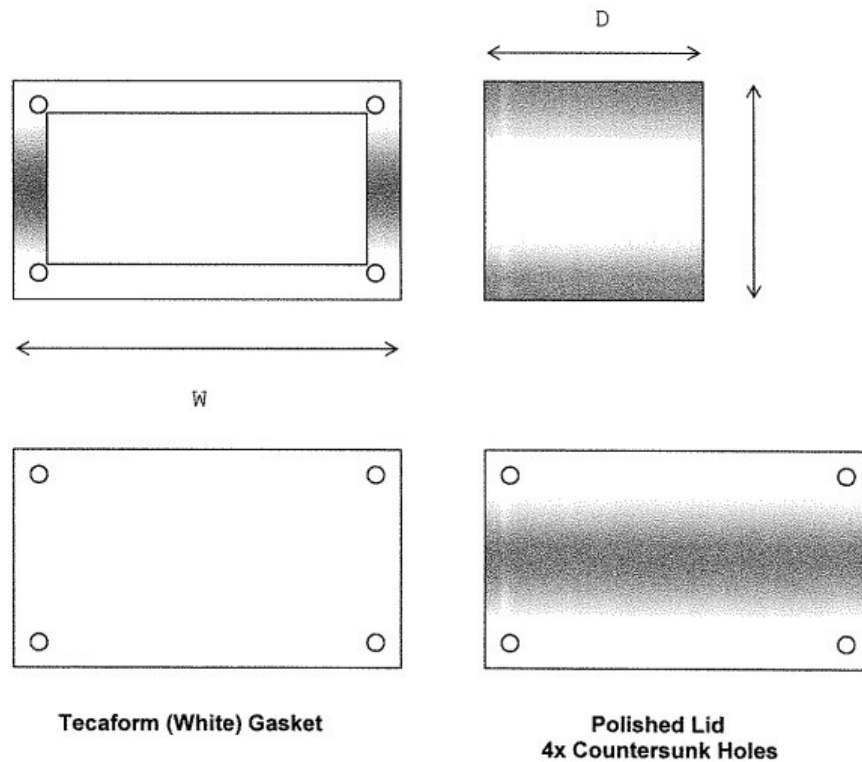

HYCON is a patented product by Dunreidy Engineering and is certified by U.L. (Underwriters Laboratories USA) UL Classification Code: In accordance with European Standard EN -IEC 61386-1 AND ** IEC 61386-21, IEC 61386-22, IEC 61386-23, IEC 61386-24 and/or IEC 61386-25, "STAINLESS STEEL CONDUIT" or "STAINLESS STEEL CONDUIT FITTING" [18EC] Dunreidy Engineering Limited: Classification Coding: 444411664414 and to European standard EN 50086

8. SOCKET AND BUSH

This component is used to enable HYCON conduit to fix to an inspection box or control panel.

DIAGRAM 12

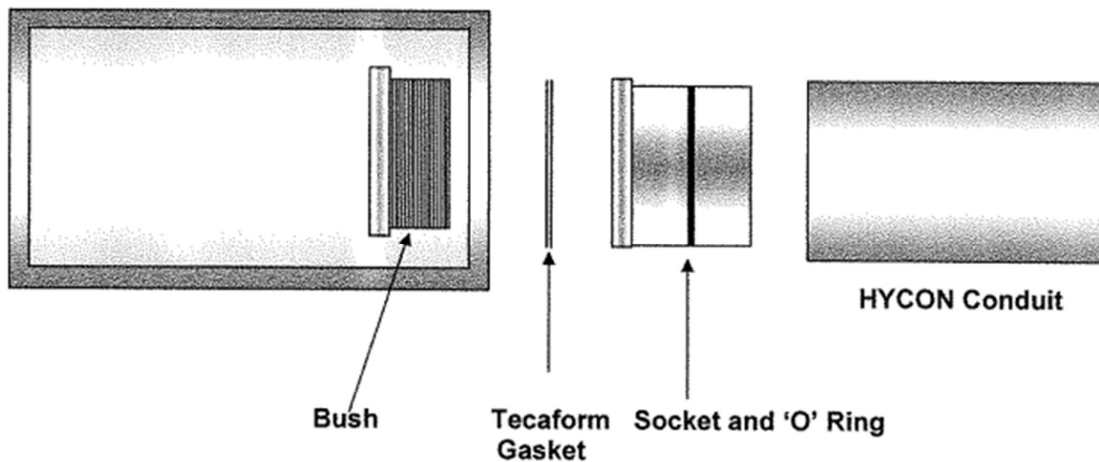

Please note:

'O' Rings are supplied with HYCON joiners, Socket and Bush and Tecaform inserts. These 'O' Rings should not be left exposed to the atmosphere for long periods prior to installation. If it is not possible to install these components within a short period, then the 'O' Rings should be removed and placed in a sealed plastic bag. The period of time for damage will greatly depend on the atmospheric conditions, an approximate estimate is about two weeks.

9. FOOT PLATE

Ideally suited where support from ground is required

DIAGRAM 13

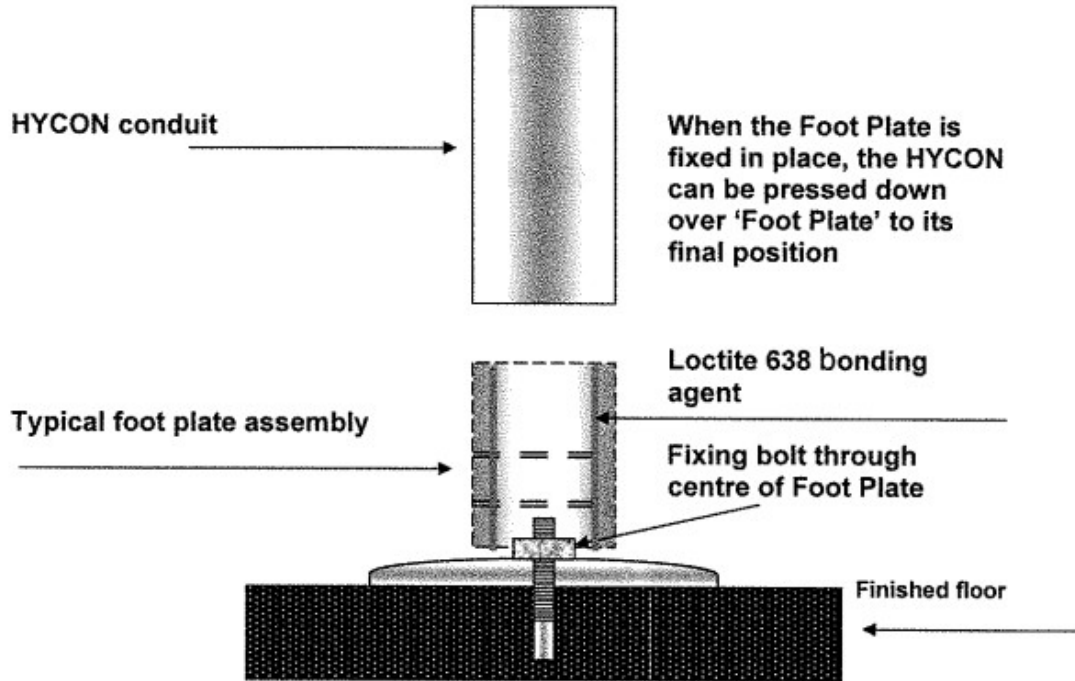

HYCON is a patented product by Dunreidy Engineering and is certified by U.L. (Underwriters Laboratories USA) UL Classification Code: In accordance with European Standard EN -IEC 61386-1 AND ** IEC 61386-21, IEC 61386-22, IEC 61386-23, IEC 61386-24 and/or IEC 61386-25, "STAINLESS STEEL CONDUIT" or "STAINLESS STEEL CONDUIT FITTING" [18EC] Dunreidy Engineering Limited: Classification Coding: 444411664414 and to European standard EN 50086

10. Expander/Reducer

DIAGRAM 14

**Available in all
sizes to order
within the
HYCON Range**

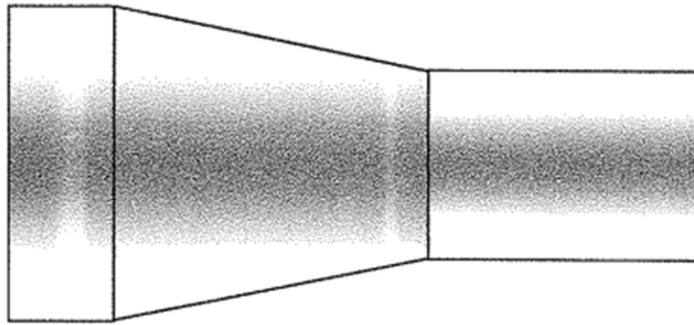

Available in all sizes to order within the HYCON Range

This HYCON product is generally used to 'reduce' conduit size and to 'expand' to accommodate larger multi-hole inserts (see Section 11 Diagram 15).

11. Inserts

11.1 Inserts are used with an appropriate cable gland or glands at the user end of the HYCON system to seal the HYCON. Inserts come in all HYCON conduit sizes and can be supplied either, drilled and tapped to customer requirements, or blank.

11.2 Inserts are generally tapped into position using a nylon mallet and do not normally require 'bonding'. If there is a possibility of undue 'straining' then 'bonding' is advisable (see Diagram 15)

4" Insert with 9 x M20 threaded holes.

DIAGRAM 15

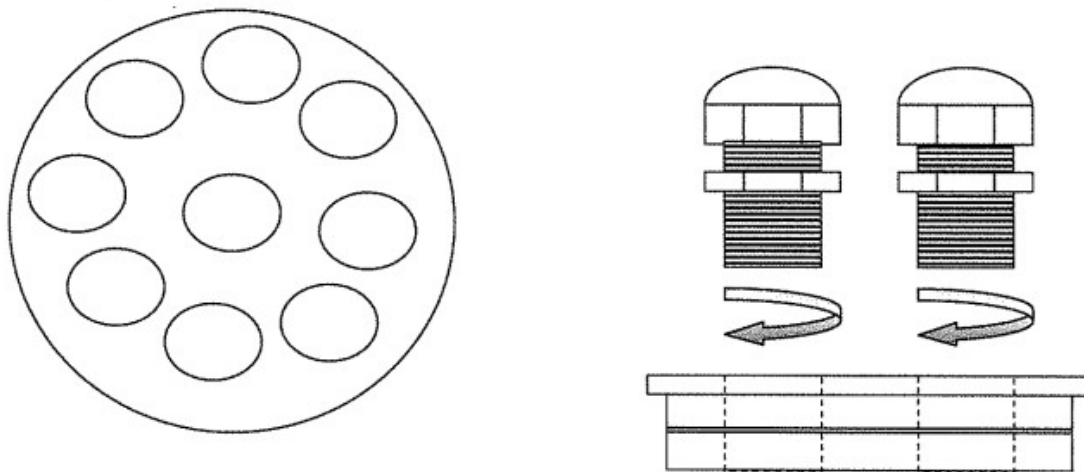

HYCON S INSTALLATION PROCEDURE

HYCON S is a Quick Install product.

HYCON S conduit and fittings are similar in all respects to HYCON O except the joining/coupling methodology is different (see Diagram 2; Page 4)

Please Note: A 3D model of all HYCON components O and S plus accessories is available on request. This will allow the specifier to use the 3D modelling at the design stage thus creating a Bill of Quantities and a costing.

CHOOSING THE CORRECT SIZE OF HYCON S

As with HYCON O it is important to select the correct size of conduit (see Section 1; Page 5) With the HYCON S system the conduits are cut to length using a rotary saw and a simple hand-held deburring tool and file is used to clean and chamfer the inside of the conduit, See photographic illustrations

It is advisable that all parties concerned with the project are in total agreement before the final 'Installation' is installed and cables drawn through.

HYCON-S conduit and fittings are available with expanded or non-expanded ends therefore it is imperative when ordering that the customer/contractor specifies clearly which ends should be expanded. (Seek technical assistance from our office if necessary)

Consideration should be given that in the case of vertical drops all overlapping joints face downwards (see Diagram 16 on the next page)

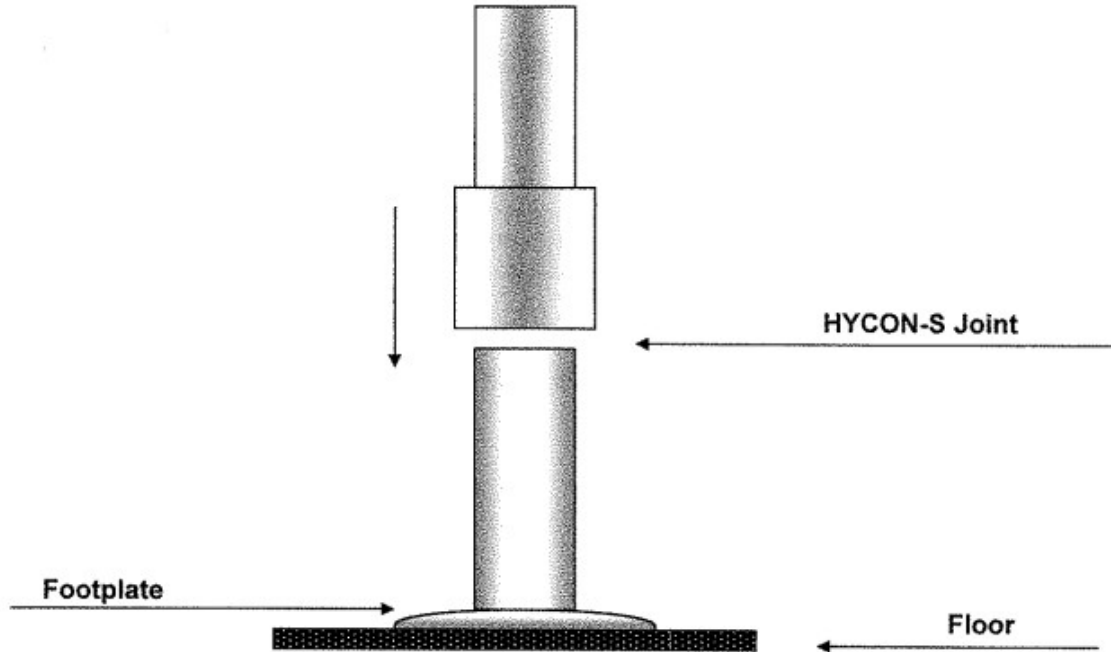
DIAGRAM 16

The HYCON S system can be installed as a sealed or unsealed system. The deciding factor on which system to use will depend on the environment in which it is installed. We recommend that if moisture is present, it should be sealed. The sealing is achieved using Loctite 5366 sealant (see photographic illustrations)

APPLICATION OF SEALANT

Sealant is applied on the non-flared end of the conduit. The location of application will be measured from the end of the conduit and will be equal to approximately half the flared length for that size conduit (see Diagram 17)

DIAGRAM 17

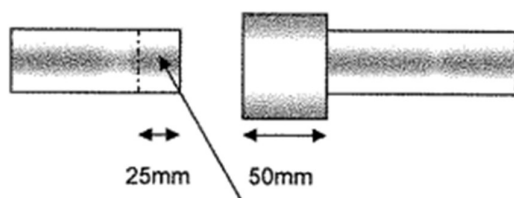

Application of sealant a full 360 deg around pipe

The HYCON S is now pushed together and can be further tightened by use of a nylon mallet. All excess sealant should now be removed. When the HYCON-S joint is pushed fully together the end of the joint can be 'chamfered off' by using the sealant. This will give a 'sloped edge' finish. The finished joint is extremely rigid and HYCON S will require the minimum of bracketing.

Some HYCON O parts will be used in the HYCON S installation.

- Socket and Bush for entering or exiting JB's or Panels
- Foot Plate for securing to wall or to floor
- Ceiling Bulkhead for entering/exiting walls or ceilings

Note: All HYCON accessories interconnect with both HYCON O and HYCON S It is mandatory that these sealing instructions are followed in order to maintain earth continuity throughout.

If sealant is not required the same procedure is used with the obvious exclusions.

As the expanded or flared sections are tapered it is important to ensure that the conduits are pushed firmly together.

This is to ensure good earth continuity. Earth continuity should be checked using the appropriate certified meters.

PHOTOGRAPHIC ILLUSTRATIONS



Rotary Saw



Facing Off Tool



File



Deburring Tool



Nylon Mallet



Bonding Agent



Sealing Agent

HYCON is a patented product by Dunreidy Engineering and is certified by U.L. (Underwriters Laboratories USA) UL Classification Code: In accordance with European Standard EN -IEC 61386-1 AND ** IEC 61386-21, IEC 61386-22, IEC 61386-23, IEC 61386-24 and/or IEC 61386-25, "STAINLESS STEEL CONDUIT" or "STAINLESS STEEL CONDUIT FITTING" [18EC] Dunreidy Engineering Limited: Classification Coding: 444411664414 and to European standard EN 50086